

# Atlas Form Studio

The Enterprise-Grade Form  
Management & Rendering Engine.

Investor Briefing | BizFirstAi Platform

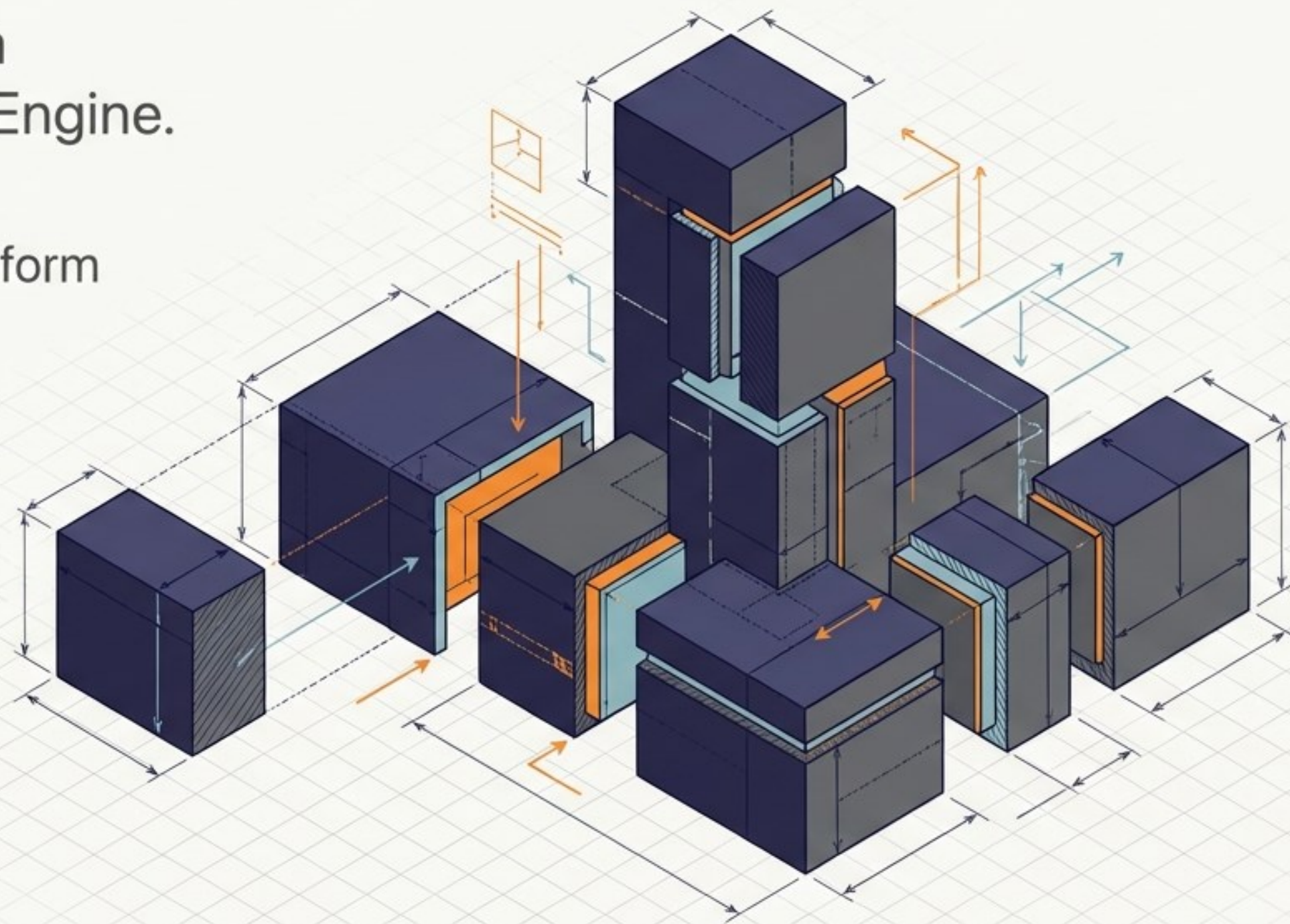

# The Hidden Bottleneck in Enterprise Development

At first glance, forms appear trivial. In reality, they are complex state machines and massive security vulnerabilities that drain engineering resources.

- **The Reality:** 90% of form development effort is spent on cross-field validation, conditional logic, OWASP security, state manager compliance audit trails, and multi-tenant isolation.
- **The Impact:** 70% of enterprise workflows require human-in-the-loop forms, yet organizations rebuild this infrastructure from scratch every time.

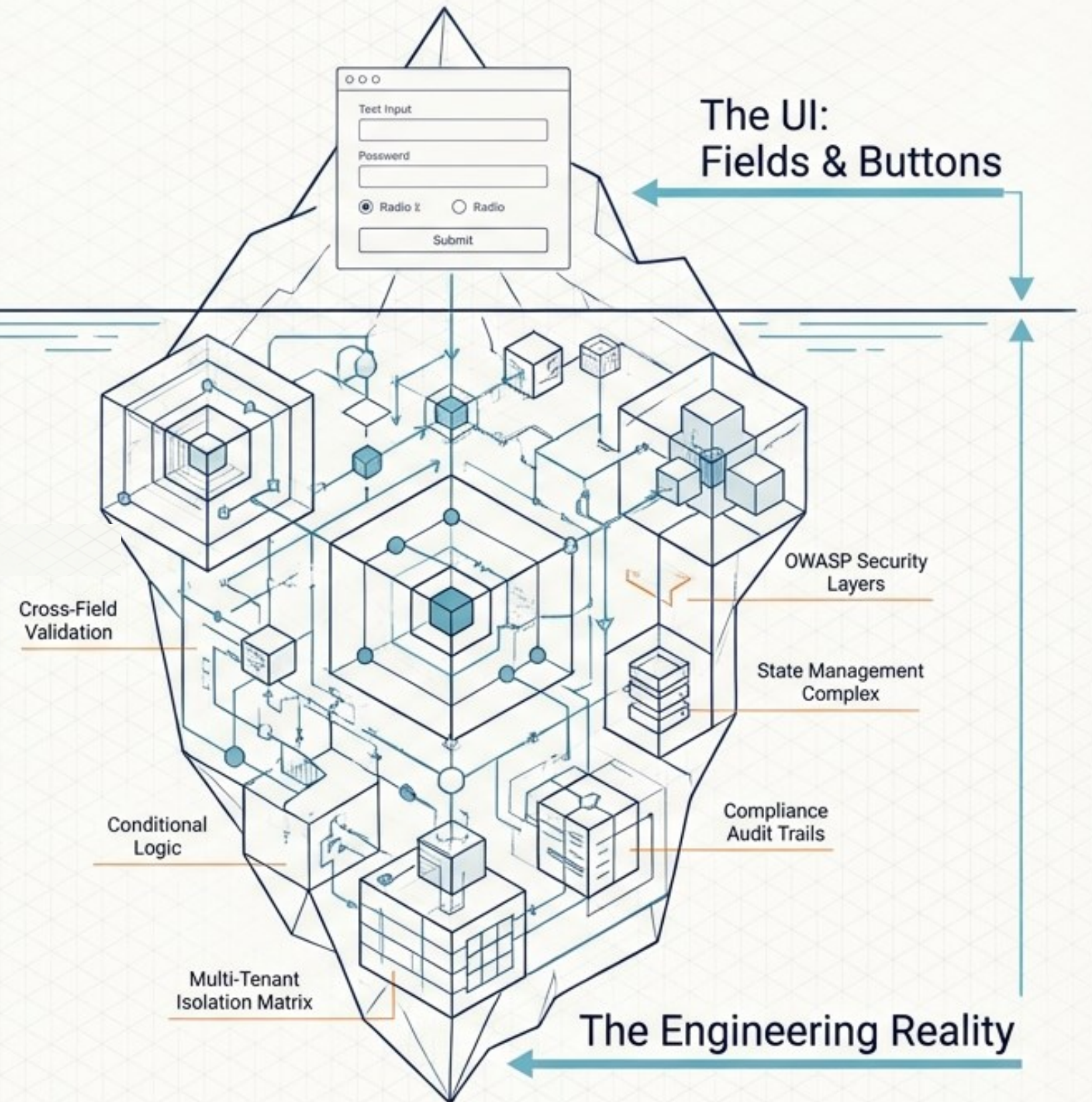

# Enterprises Are Forced Into a Lose-Lose Choice

## The Custom Code Trap

- Metric: Costs **\$50k–\$200k** per form workflow.
- Time: Requires **3–6 months** to deploy.
- Reality: A maintenance nightmare lacking standardization, leading to severe security risks and technical debt.

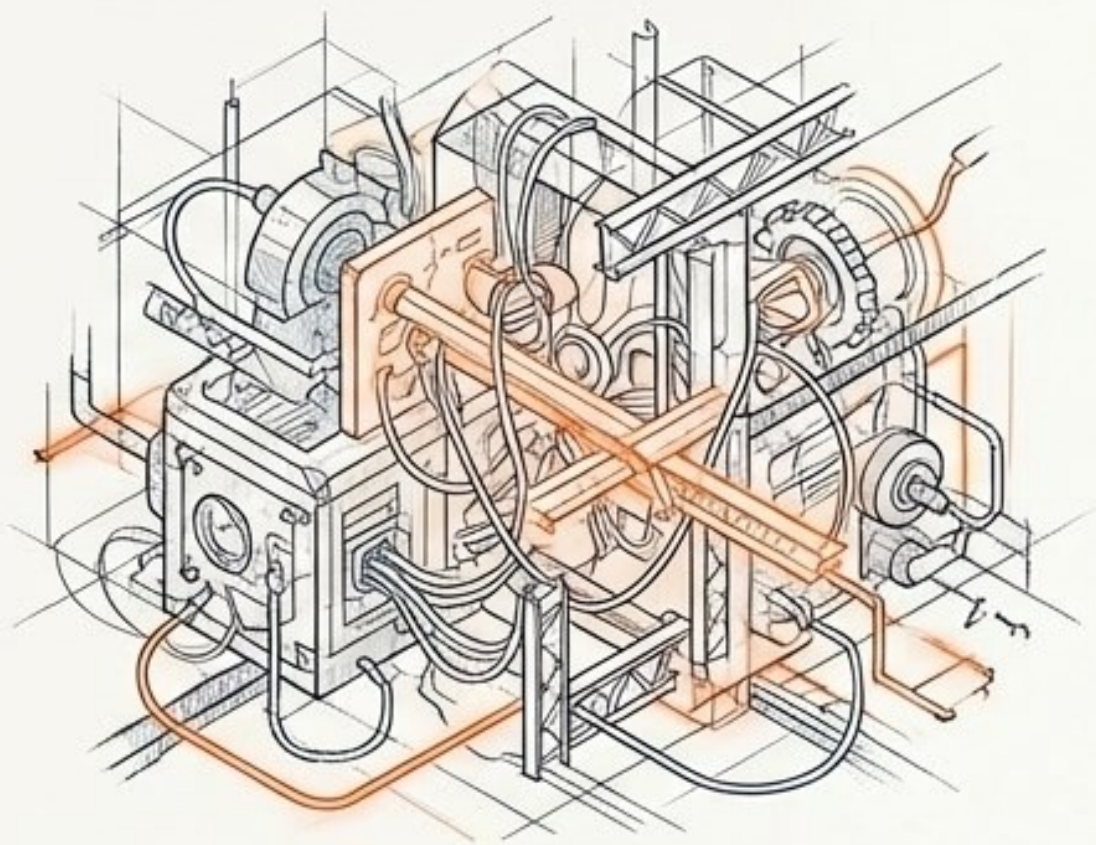

## The Lightweight SaaS Trap

- Examples: **JotForm, Typeform**.
- Reality: Consumer-grade security. Severe vendor lock-in. Lacks native workflow integration, fine-grained authorization, and the immutable audit trails required by regulated industries.

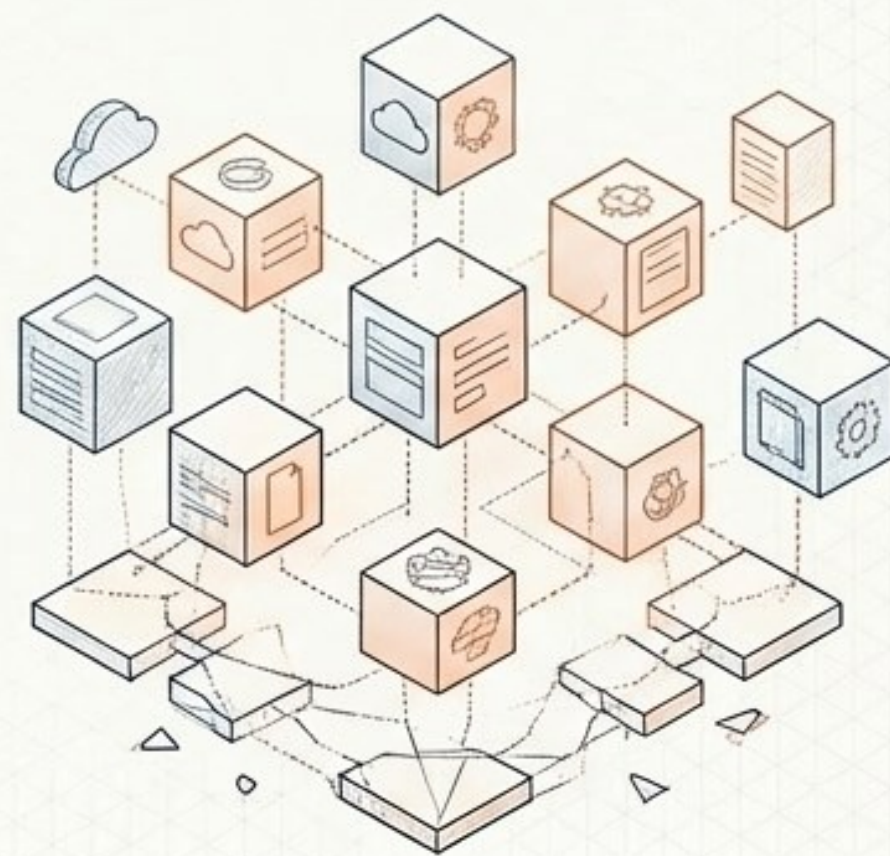

Forms represent **30–40%** of enterprise workflow execution but lack standard, secure infrastructure.

# The Infrastructure for Enterprise Data Collection

Atlas Forms is a production-ready, low-code rendering engine that separates form authoring from application logic, empowering business analysts while exceeding enterprise engineering standards.

Visual Designer  
(No-Code)

Form Engine  
(Logic)

Data Ocean  
(Storage)

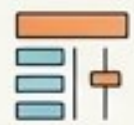
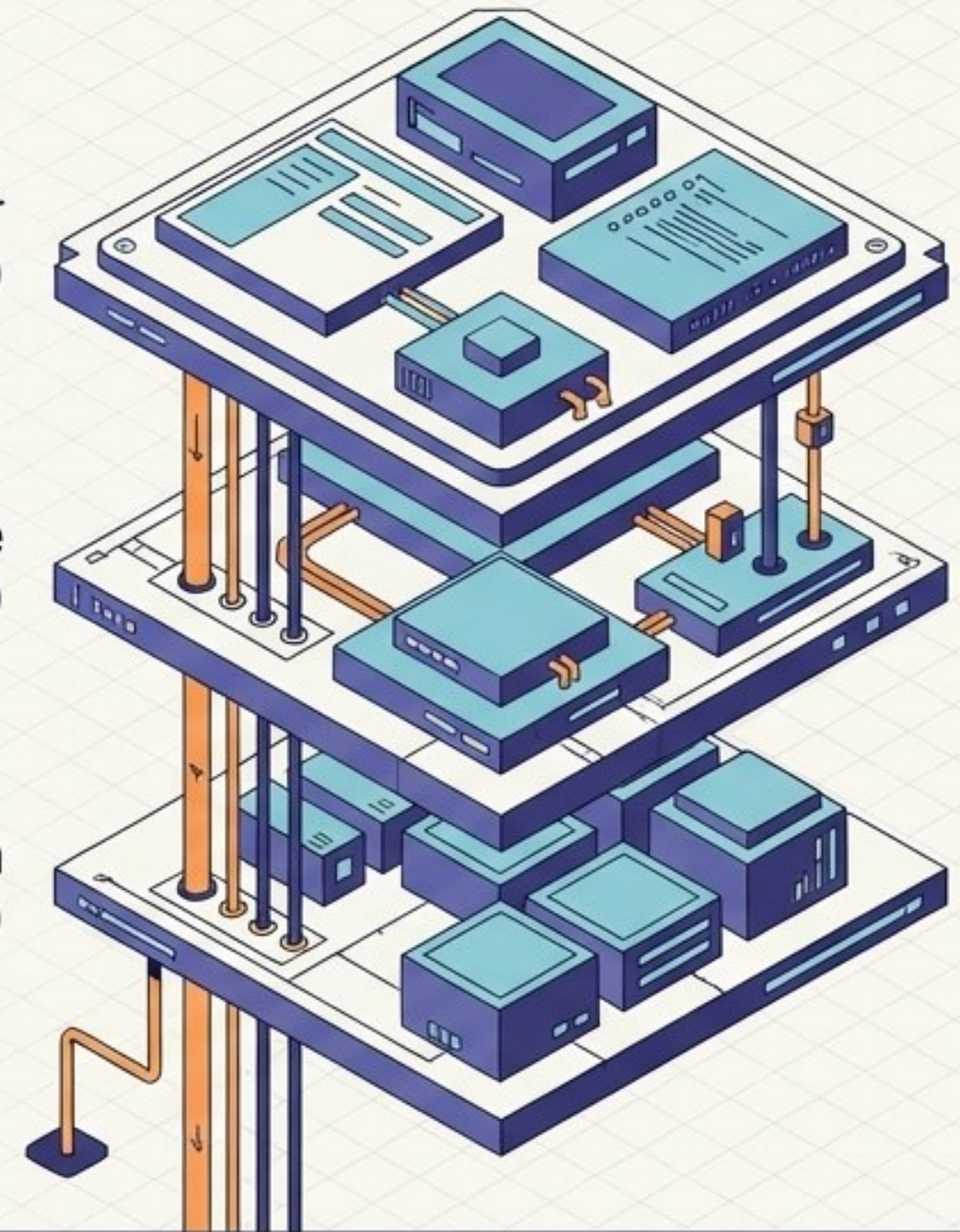

**89+**  
Control Types



**100%**  
TypeScript Strict Mode



**Sub-100ms**  
Load Times



**100k+**  
Concurrent Scale

# The Technical Moat: Server-Side Schema Inheritance

Enterprises manage hundreds of form variants. Atlas introduces server-side Schema Inheritance to eliminate duplicate code and maintenance debt.

The Impact: Update a base template once; changes propagate instantly to all child forms across the organization. Zero developer coordination required.

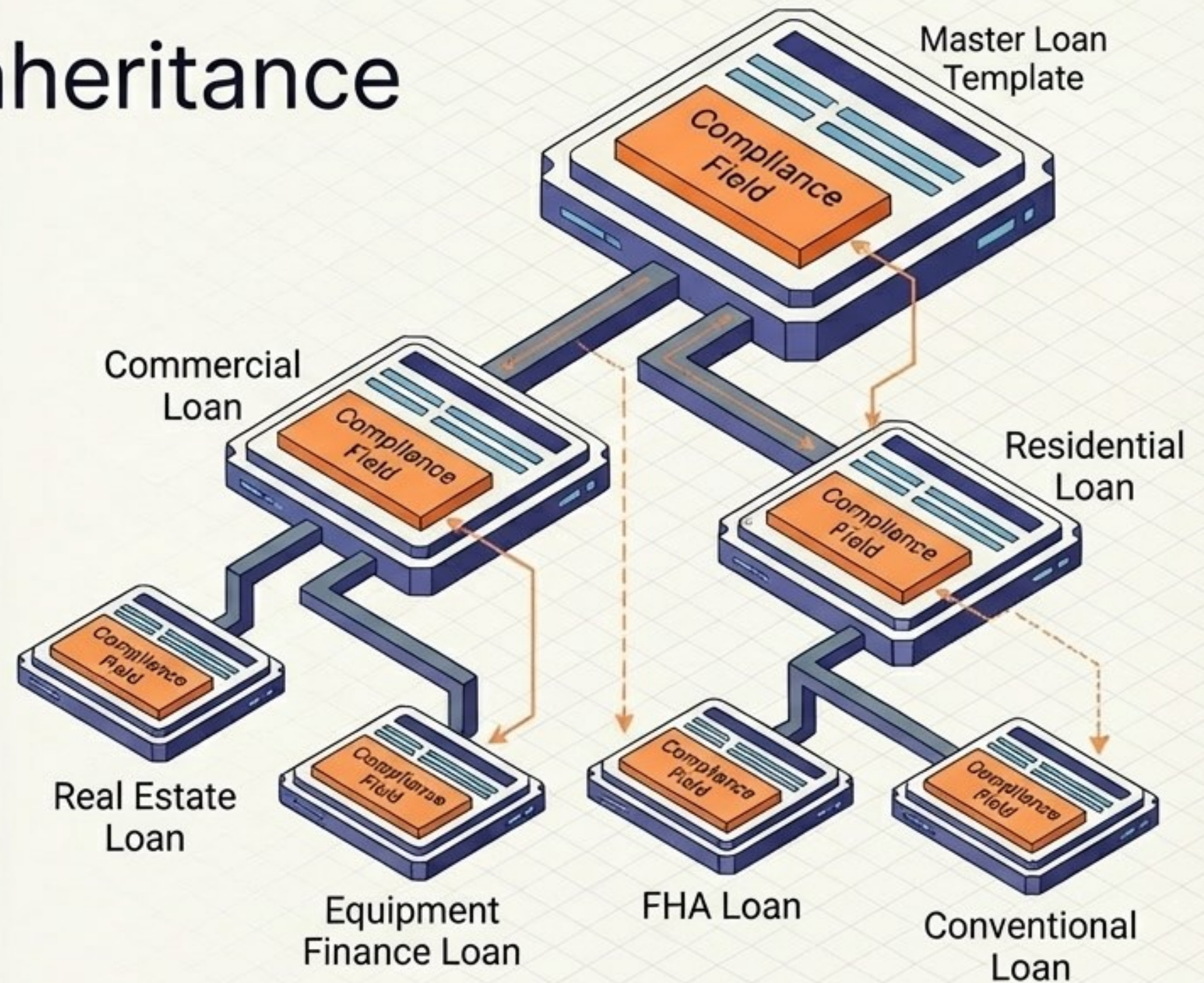

# Security as a Fundamental Platform Property

Input forms are the #1 attack vector in web apps (OWASP A03:2021). Atlas enforces compliance structurally, rather than relying on individual developer discipline.

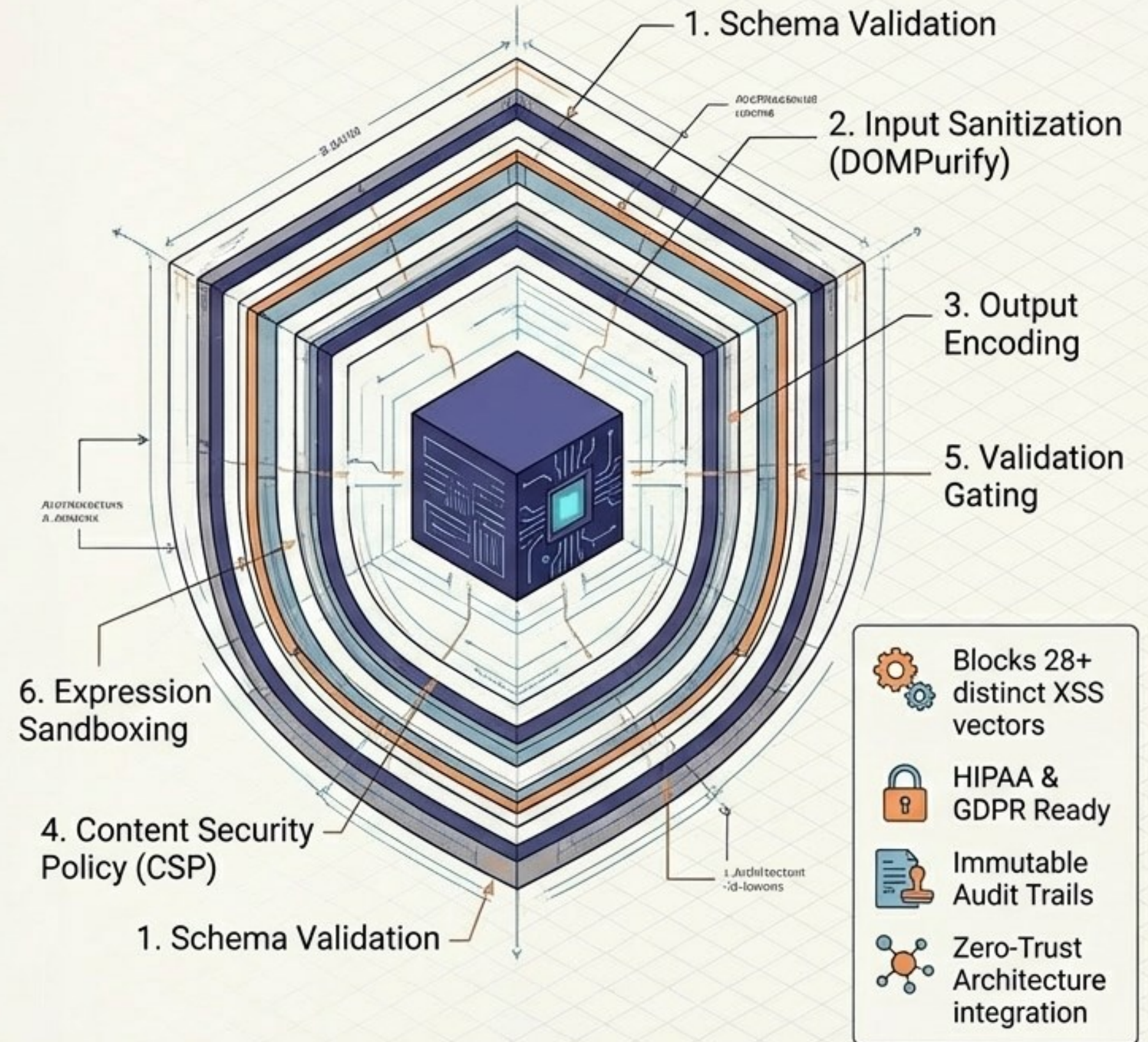

# Seamless Ecosystem Integration

Unlike standalone form tools, Atlas natively integrates with the BizFirstAi execution engine.

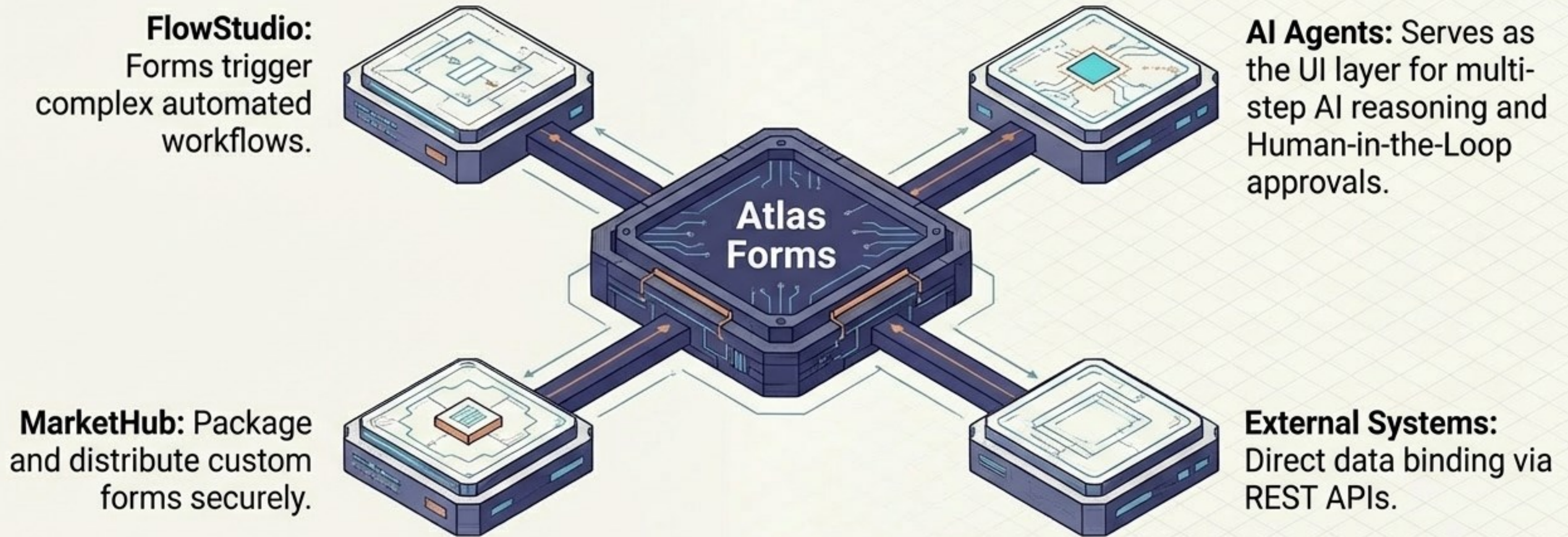

# Capitalizing on a \$1.8B+ Form Management Market

## Primary TAM:

**\$1.8B** primary Total Addressable Market for Form Management.

## Growth Trajectory:

Growing at a **15% CAGR**, projected to reach **\$8-\$10B** by 2030.

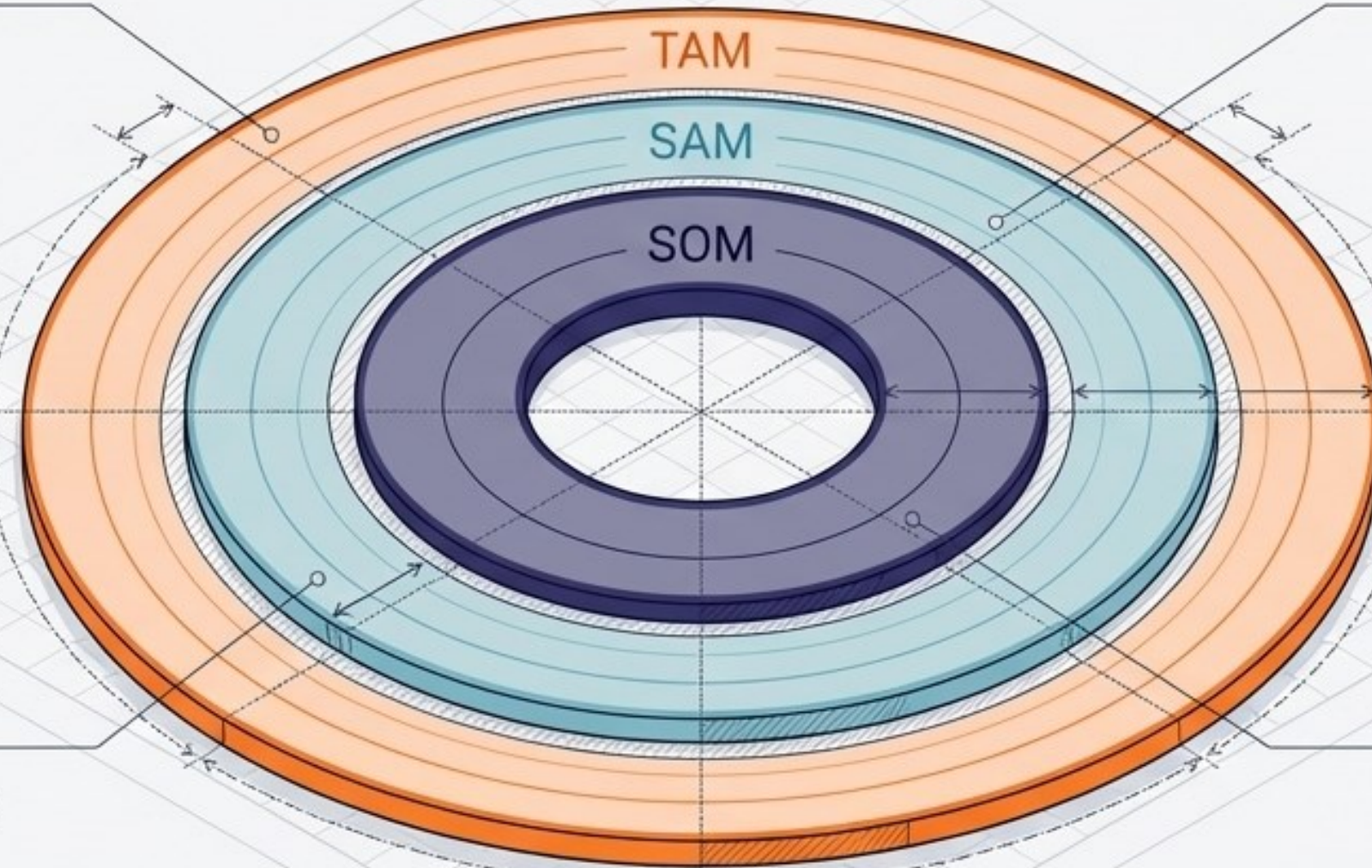

## Adjacent Markets:

Atlas sits at the highly lucrative intersection of Workflow Automation (**\$1.3B**) and Identity/Compliance (**\$630M**), part of a broader **\$6.2B** ecosystem opportunity.

## Key Growth Drivers:

Rapid enterprise digitalization, mobile-first operational demands, and strictly escalating compliance regulations (HIPAA, SOX, PCI-DSS).

# Land and Expand in High-Value Regulated Verticals

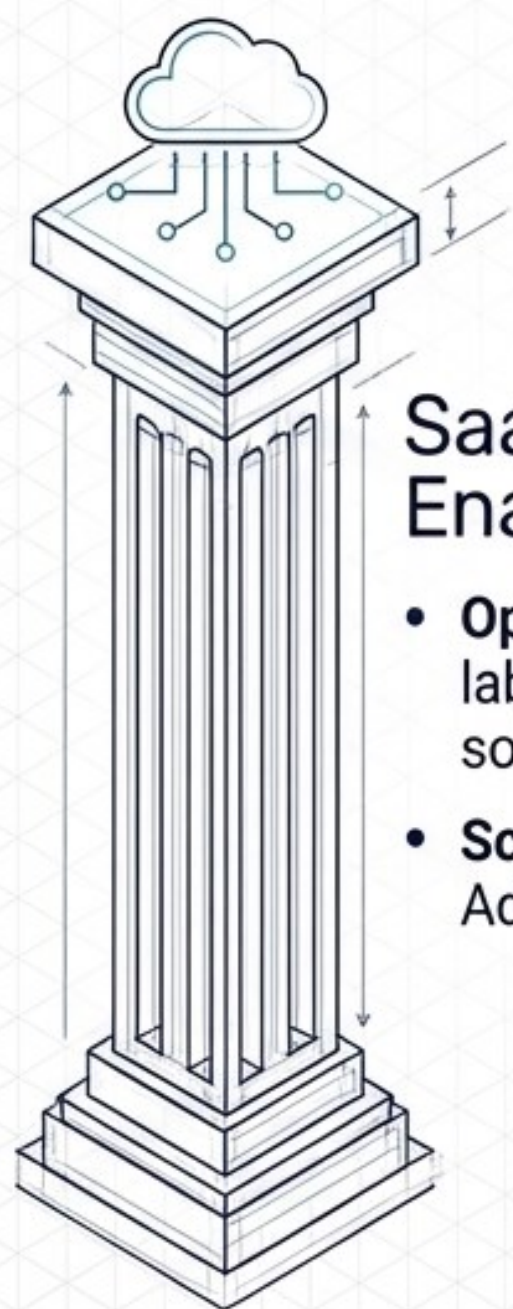

## SaaS Enablement

- **Opportunity:** White-label Atlas inside other software products.
- **Scale: \$1B+** Addressable Market.

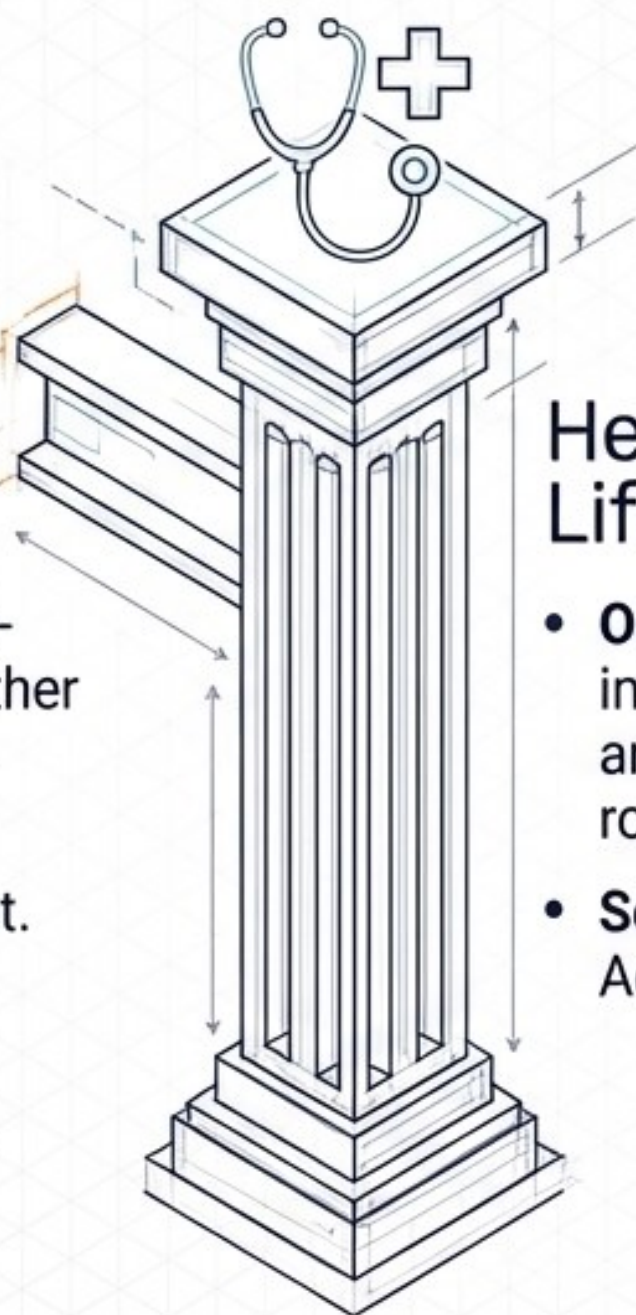

## Healthcare & Life Sciences

- **Opportunity:** Patient intake, clinical trials, and HIPAA-compliant routing.
- **Scale: \$600M+** Addressable Market.



## Financial Services

- **Opportunity:** KYC/AML onboarding, loan origination, and SOX audit trails.
- **Scale: \$800M+** Addressable Market.

# Unique Positioning in a Fragmented Market

Capability	Atlas Forms	SMB SaaS (JotForm/Typeform)	Custom Dev	Legacy Enterprise (SAP)
89+ Advanced Controls	✓	✗	✓ - High Cost	✓
Native Workflow Integration	✓	⚠ - via Zapier	✓	✓
Enterprise Security (OWASP)	✓	⚠	⚠ - inconsistent	✓
Schema Inheritance	✓	✗	✗	⚠
White-Label / Multi-Tenant	✓	✗	✓ - High Cost	✗

Atlas occupies the definitive white space: Enterprise power at low-code speeds.

# Transforming the Cost Curve of Development

## Speed to Market

Accelerated from 3–4 weeks (custom build) down to 2–3 days (80% faster deployment).



## Cost Reduction



Delivers a 60–70% reduction in developer time allocation, freeing engineers for core product work.

## Data Quality

Achieves a 95% error reduction at the point of entry via 40+ built-in, real-time validators.

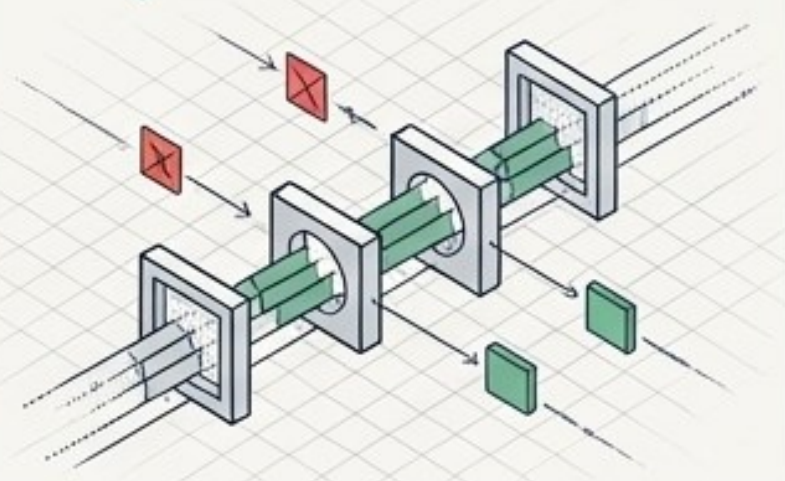

Developer Time

Core Product Work

# Highly Efficient SaaS Economics

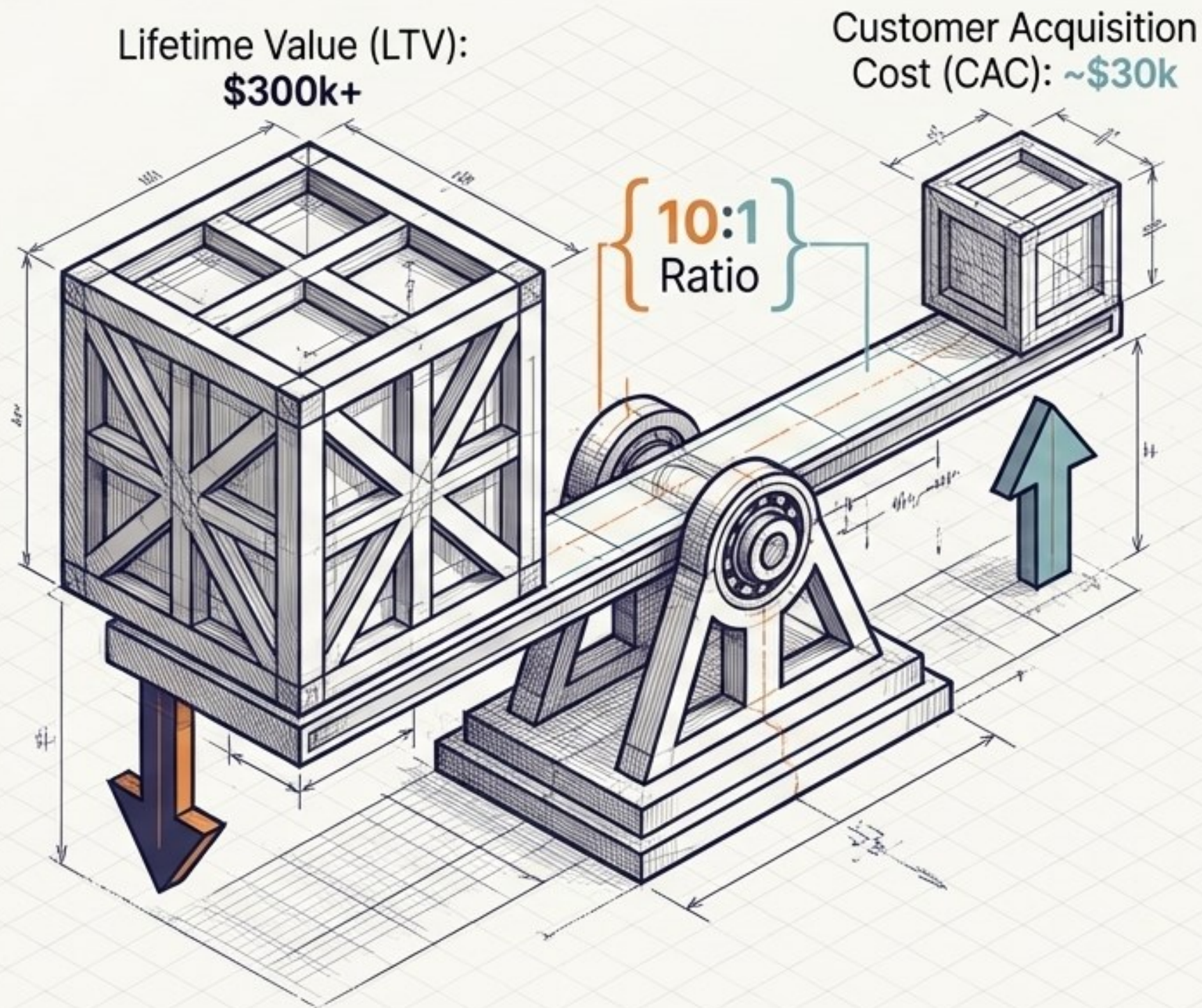

## Key SaaS Metrics



- **LTV / CAC Ratio:** Targeting **10:1** (Industry standard is 3:1).



- **Customer Acquisition Cost (CAC):** Highly efficient at **~\$30k**, driven by product-led growth and ecosystem effects.



- **Average Contract Value (ACV):** **\$100k – \$300k** for Enterprise deployments.



- **Gross Margins:** **80%+** supported by a perpetual/multi-tenant SaaS model.



- **Payback Period:** **< 3 months**.



- **Lifetime Value (LTV):** **\$300k+** due to deep operational stickiness.

# The Future: AI-Powered Workflow Orchestration

Becoming the definitive UI layer for AI Agents collecting and validating human input.



Q2 2026: AI-Powered Form Generation  
(Natural Language to JSON Schema)  
& Advanced Analytics.

Q3 2026: Mobile-First Optimization  
& Touch-native controls.

Q4 2026: Real-Time  
Multi-User Collaboration  
(Multi-player editing).

# The Investment Thesis: Why Atlas Forms Wins

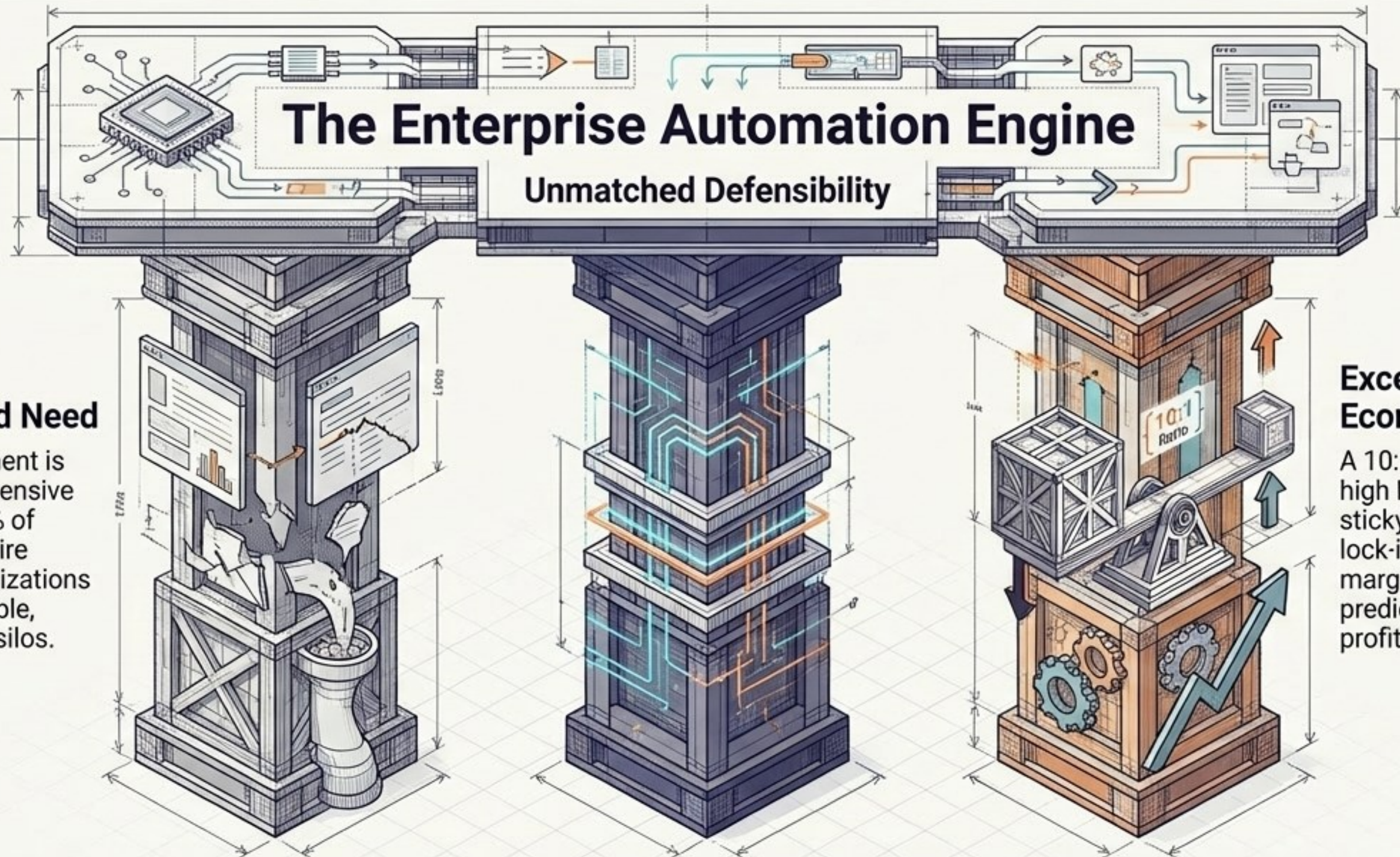

# Build the Foundation of Enterprise Automation

Join us in scaling the definitive form and workflow rendering engine.

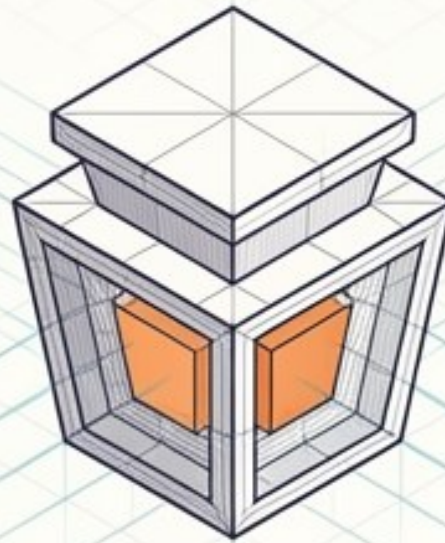

**BizFirstAi Platform**

Investor Relations

[Contact Details]